

Hypertherm®

powermax1000™ G3 SERIES™

Hand torch parts



Powermax1000



T60 Torch

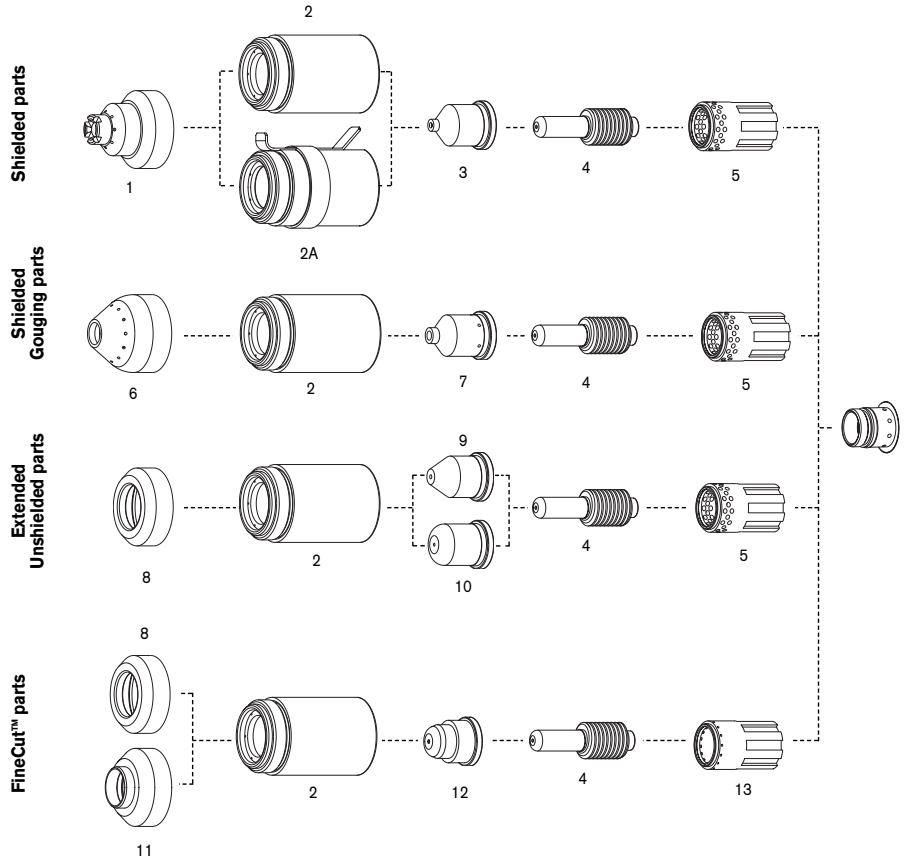

	ITEM NUMBER	PART NUMBER	DESCRIPTION	QUANTITY PER PACKAGE
Shielded parts	1	120929	Shield	1
	2	120928	Cap, Retaining	1
	2A	220061	Cap, Shield, Ohmic Contact	1
	3	120931	Nozzle, 60 Amp	5
	3	120932	Nozzle, 40 Amp	5
	4	120926	Electrode	5
Shielded Gouging parts	5	120925	Swirl Ring	1
	6	120977	Shield, Gouging	1
	2	120928	Cap, Retaining	1
	7	220059	Nozzle, Gouging	5
Extended Unshielded parts	4	120926	Electrode	5
	5	120925	Swirl Ring	1
	8	120979	Deflector	1
	2	120928	Cap, Retaining	1
	9	220007	Nozzle, Extended, 60 Amp	5
	10	220006	Nozzle, Extended, 40 Amp	5
FineCut™ parts	4	120926	Electrode	5
	5	120925	Swirl Ring	1
	8	120979	Deflector	1
	11	220325	Deflector, CE, FineCut	1
	2	120928	Cap, Retaining	1
	12	220329	Nozzle, T60/T80/T100, FineCut	5
	4	120926	Electrode	5
	13	220327	Swirl Ring, FineCut	1

Genuine Hypertherm Consumables

The only way to ensure maximum performance

WARNING

In countries following CE standards, shielded consumable parts must be used for hand cutting applications

Powermax1000 Safety Trigger Torch Assembly (T60)



T60 Torch

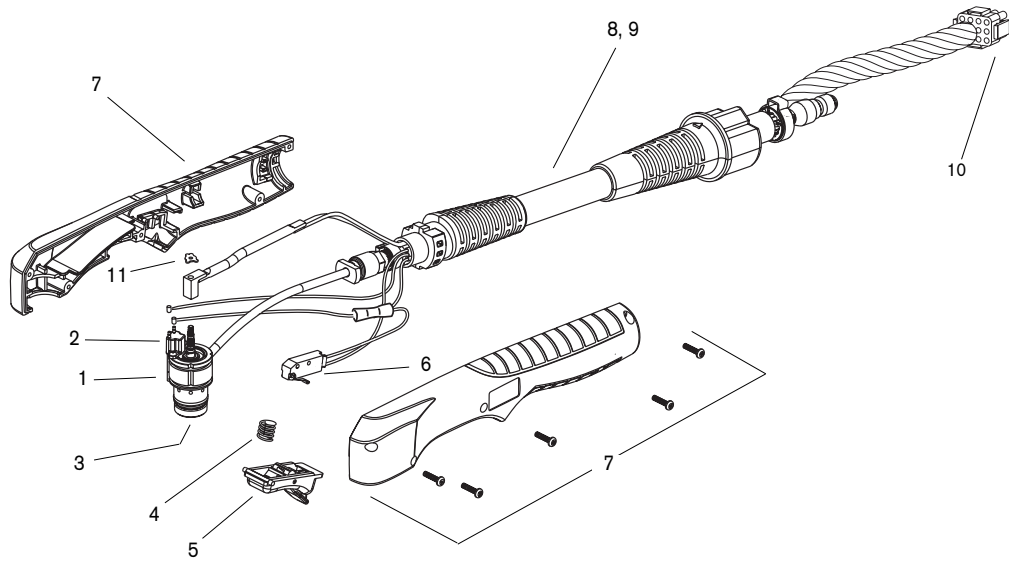

ITEM NUMBER	PART NUMBER	DESCRIPTION
	083172^	T60 Hand Torch Assembly, 25' (7.6 m)
	083171^	T60 Hand Torch Assembly, 50' (15.2 m)
1	128564	Kit: T60/T80 Torch Main Body Replacement
2	128639	Kit: Cap Sensor Switch Replacement
3	128521	Kit: T60/T80, T60M/T80M Torch Head Repair
4	027254	Trigger Spring
5	002244	Safety Trigger Assembly
6	128642	Kit: T60/80 Start Switch Replacement
7	128644	Kit: T60 Torch Handle Replacement
8	128681	Kit: T60 Lead Replacement 25' (7.6 m)
9	128682	Kit: T60 Lead Replacement 50' (15.2 m)
10	128638	Kit: ETR Connector Repair (Regional Repair Centers Only)
	027889	Retaining Clip

^ Assembly includes consumables

Hypertherm, Powermax, G3 Series, FineCut and PAC are trademarks of Hypertherm, Inc. and may be registered in the United States and/or other countries.

Hypertherm®

The world leader in
plasma cutting technology™

www.hypertherm.com

Hypertherm, Inc. USA 603-643-3441 Tel 603-643-5352 Fax consumable.info@hypertherm.com

Hypertherm Automation, LLC USA 603-298-7970 Tel 603-298-7977 Fax info@hyperthermautomation.com

Hypertherm Plasmatechnik, GmbH Deutschland 49 6181 58 2100 Tel 49 6181 58 2134 Fax
HTDeutschland.info@hypertherm.com

Hypertherm (S) Pte Ltd. Singapore 65 6 841 2489 Tel 65 6 841 2490 Fax
HTSingapore.info@hypertherm.com

Hypertherm UK, Ltd England 44 1928 579 074 Tel 44 1928 579 604 Fax HTUK.info@hypertherm.com

France 00 800 3324 9737 Tél 00 800 4973 7329 Fax HTFrance.info@hypertherm.com

Hypertherm S.r.l. Italia 39 02 725 46 312 Tel 39 02 725 46 400 Fax HTItalia.info@hypertherm.com

Hypertherm Europe B.V. Nederland 31 165 59 69 08 Tel 31 165 59 69 01 Fax
HTEurope.info@hypertherm.com

Japan 81 05 5975 7387 Tel 81 05 5975 7376 Fax HTJapan.info@hypertherm.com

Hypertherm Brasil Ltda. 55 21 2278 6162 Tel 55 21 2578 0947 Fax HTBrasil.info@hypertherm.com