

Powerful Solutions For Welding And Cutting Automation

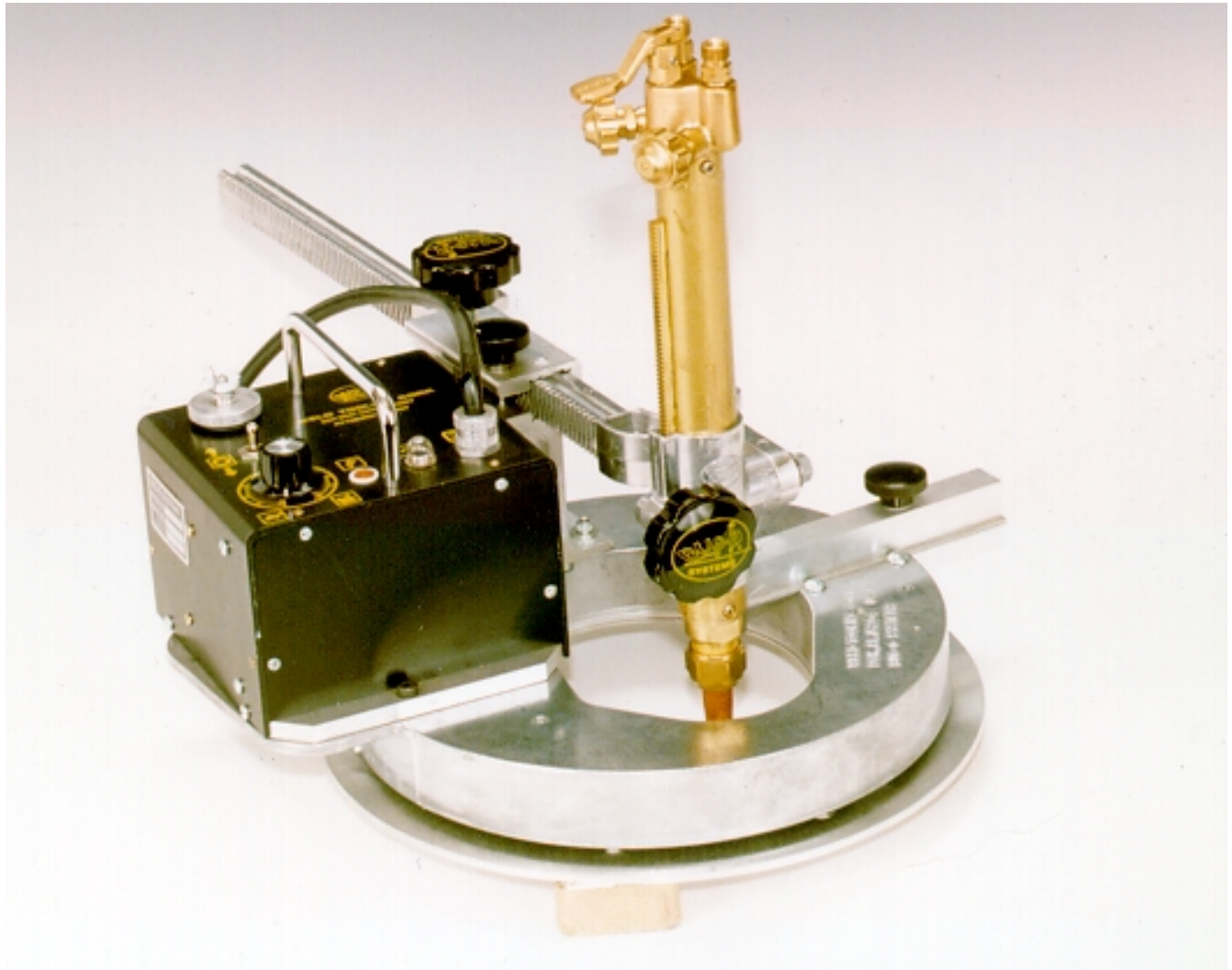

DC HOB-O HOLE BORER

**A Lightweight Precision Hole Borer, Beveler,
And Welder That Is Easy To Use!**



The **DC HOB-O** lightweight hole borer is easily carried to the work, and is quickly centered on the workpiece - all you need is a single center-punch mark. Set the hole radius on the built-in scale, light the torch, start your cut and hit the switch to make smooth accurate holes in any position; virtually eliminating the need for grinding and touchup. This flame-cutting machine will cut holes from 1" to 8" (25 mm to 200 mm) inside diameter and from 14 $\frac{1}{2}$ " to 48" (368 mm to 1220 mm) outside diameter. When mounted with magnets, each magnet foot is covered with a shield to protect it from direct flame and heat.

PATENTS WORLDWIDE



BUG-O SYSTEMS
A DIVISION OF WELD TOOLING CORPORATION



3001 WEST CARSON STREET PITTSBURGH, PENNSYLVANIA USA 15204-1899
PHONE: 1-800-245-3186 <http://www.bugo.com> TELEFAX: 1-412-331-0383



DC HOB-O HOLE BORER

Technical Data:

Power Requirements: HOB-2303 120 VAC/50-60/1
 HOB-2323 240 VAC/50-60/1
 HOB-2313 42 VAC/50-60/1

Dimensions: 15.06"L x 28.50"W x 10.50"H
 (383 mm x 724 mm x 267 mm)

Net Weight: 30 lbs. (13.6 kg)
Shipping Weight: 35 lbs. (15.9 kg)

Speed: See Chart

Capacity: See Chart

Drives: The HOB-O Drive Unit is a solid-state DC drive.

Capacities and Speed Ranges (HOB-5100-F 150:1 Ratio)			
DIA. INCH	INCH SPEED IPM	DIA. mm	METRIC SPEED mm/min.
1	.4-8	25	10-200
4	1.6-33	100	40-800
8	3.3-66	200	80-1600
15	6-125	380	150-3000
20	8-160	500	200-4000
25	10-200	600	250-5000
30	12-250	750	300-6000
35	14-290	900	370-7500
40	16-330	1000	400-8000
45	18-375	1100	450-9000
48	20-400	1200	500-10000

Speed range can also be found from formula:
 Minimum speed per minute = (0.4 x diameter).
 Maximum speed per minute = (8 x diameter).

NOTE: Individual machines may operate at speeds lower than minimum shown in chart.



The slug in No. 1, clean scrap, easily handled and readily sold.

Dimensions:

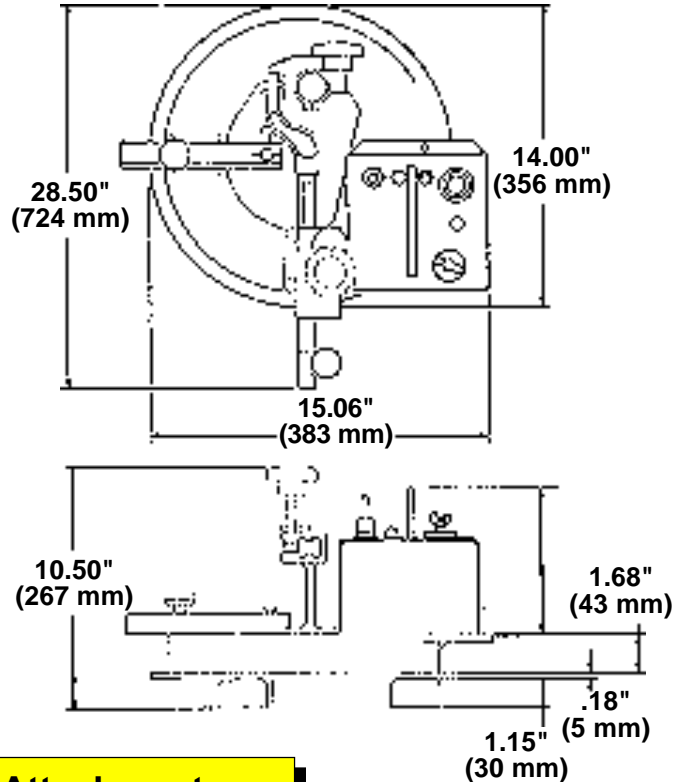

Attachments:

The **HOB-2080 Blind Area Kit** allows you to make smooth accurate cuts while eliminating blind area interference when using the DC HOB-O Hole Borer. It will cut holes from 8" up to 14 1/2" (203 mm to 368 mm). It is lightweight and attaches easily onto the machine.

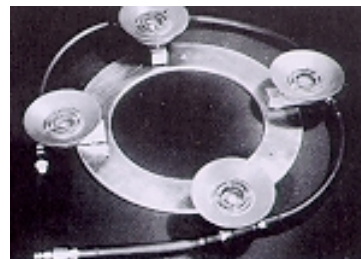
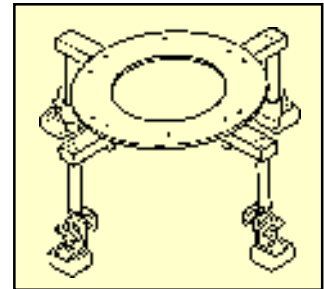

HOB-1140 Vacuum Base can also be mounted on all HOB-O units for use on non-ferrous materials. The vacuum feet adjust to the work surface. Use with ARV-1020 Vacuum Pump Kit.